



EUROPEAN INSPECTION AND CERTIFICATION COMPANY S.A.

**EU TYPE-EXAMINATION CERTIFICATE FOR SAFETY COMPONENTS
ACCORDING TO EUROPEAN LIFT DIRECTIVE 2014/33/EU ANNEX IV (MODULE B)**

Certificate Number:	SCMB.0118 rev.01
Certificate Expiry Date:	18/09/2027
Applicant/Certificate Holder (Name & Address):	KÖHLER Elevator GmbH/ Carl-Legien Straße 15 63073 Offenbach am Main, Germany
Manufacturer (Name & Address):	Same as Applicant
Date of Submission:	13/08/2017
Test Laboratory:	Testing performed in the premises of the manufacturer
Date and Number of test report:	20.03.2018 / SCMB.0118TR
Approved Type of locking device:	Landing Door Locking Device
Application of locking device:	Gravity, Compressing Spring
Model of locking device:	KEG-161A
Standard(s):	EN81-50:2014
Reference Standard(s):	EN81-20:2014
Type of rated voltage:	AC/DC
Values of rated voltage:	230V/110V
Type of rated current:	AC/DC
Values of rated current:	0.3A/0.2A
*Necessary force to actuate:	--

**for flag type door locking device only*

EUROCERT SA, aforementioned notified body with identification number 1128, ascertains and certifies that above safety component satisfy the safety requirements of the European Directive 2014/33/EU.

The manufacturer is authorized to provide the safety component described above with the CE Mark as displayed below:

CE 1128

Preconditions:

It is required that the above safety equipment must always come with a declaration of conformity and the relevant instructions of use.

INSPECTOR

CHAD WANG

Athens, 27/03/2018



FOR EUROCERT SA

KONSTANTINOS PSYCHOGIOS
Construction Products and Laboratories
Manager

Please check the validity of the certificate from our website using the password H64Kcf8z



Inspections
Cert No.: 53

89, CHLOIS STR. & LIKOVRISEOS, 144 52 METAMORFOSI, ATHENS, GREECE
Tel.: ++30 210 62.52.495, 30 210 62.53.927 - Fax: ++30 210 62.03.018
Internet site: www.eurocert.gr - e-mail: eurocert@otenet.gr





EUROPEAN INSPECTION AND CERTIFICATION COMPANY S.A.

ANNEX A TO CERTIFICATE SCMB.0118 rev.1

DESIGN DRAWINGS

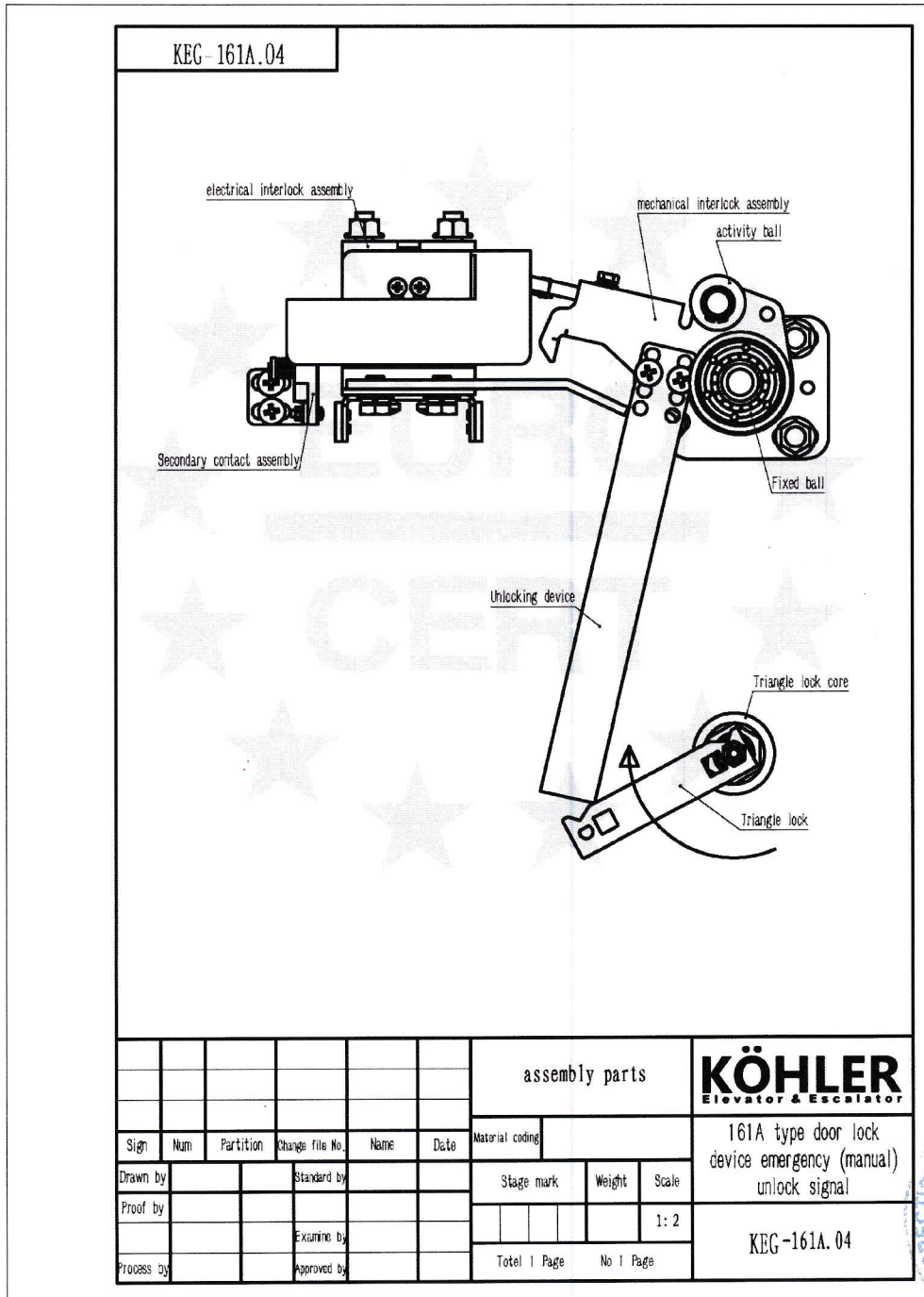

Inspections
Cert No.: 53

89, CHLOIS STR. & LIKORISEOS, 144 52 METAMORFOSI, ATHENS, GREECE
 Tel.: ++30 210 62.52.495, 30 210 62.53.927 - Fax: ++30 210 62.03.018
 Internet site: www.eurocert.gr - e-mail: eurocert@otenet.gr





EUROPEAN INSPECTION AND CERTIFICATION COMPANY S.A.

ANNEX A TO CERTIFICATE SCMB.0118 rev.1

DESIGN DRAWINGS

KEG-161A.00

Front view

back view

3	GJZF1.06(L)	auxiliary contact member	1	assembly parts	
2	GJZF1.08(L)	mechanical interlock of 161A door lock	1	assembly parts	
1	GJZF1.07(L)	electrical interlock assembly	1	assembly parts	0.3
Ordinal Number	Code	Name	Num	Material	Quantity

				assembly parts		KÖHLER
Sign	Num	Partition	Change File No	Name	Date	
Drawn by		Standard by		Stage mark	Weight	Scale
Proof by		Examine by				2:3
Process by		Approved by		Total Page	No. Page	

The Technical Requirements,

1. after assembly, the moving parts are flexible;

2. with the requirements, lock hook 7mm, only to allow the door lock contact with electrical contacts;

3. Rated Voltage: AC220V/50Hz 10V, Rated Current: AC0.3A/DC0.2A

Certificate History

Revision No.	Description	Issue Date
0	Original Certificate	19/09/2017
1	Updated test report	27/03/2018



Inspections
Cert No.: 53

89, CHLOIS STR. & LIKORISEOS, 144 52 METAMORFOSI, ATHENS, GREECE
Tel.: ++30 210 62.52.495, 30 210 62.53.927 - Fax: ++30 210 62.03.018
Internet site: www.eurocert.gr - e-mail: eurocert@otenet.gr

